



Single Supply / Low Power / 256-tap / SPI bus

## X9271

### Single Digitally-Controlled (XDCP™) Potentiometer

#### FEATURES

- 256 Resistor Taps
- SPI Serial Interface for write, read, and transfer operations of the potentiometer
- Wiper Resistance, 100Ω typical @  $V_{CC} = 5V$
- 16 Nonvolatile Data Registers
- Nonvolatile Storage of Multiple Wiper Positions
- Power On Recall. Loads Saved Wiper Position on Power Up.
- Standby Current < 3μA Max
- $V_{CC}$ : 2.7V to 5.5V Operation
- 50KΩ, 100KΩ versions of End to End Resistance
- 100 yr. Data Retention
- Endurance: 100,000 Data Changes per Bit per Register
- 14-Lead TSSOP, 16-Lead CSP (Chip Scale Package)
- Low Power CMOS

#### DESCRIPTION

The X9271 integrates a single digitally controlled potentiometer (XDCP) on a monolithic CMOS integrated circuit.

The digital controlled potentiometer is implemented using 255 resistive elements in a series array. Between each element are tap points connected to the wiper terminal through switches. The position of the wiper on the array is controlled by the user through the SPI bus interface. The potentiometer has associated with it a volatile Wiper Counter Register (WCR) and a four nonvolatile Data Registers that can be directly written to and read by the user. The contents of the WCR controls the position of the wiper on the resistor array through the switches. Powerup recalls the contents of the default data register (DR0) to the WCR.

The XDCP can be used as a three-terminal potentiometer or as a two terminal variable resistor in a wide variety of applications including control, parameter adjustments, and signal processing.

#### FUNCTIONAL DIAGRAM

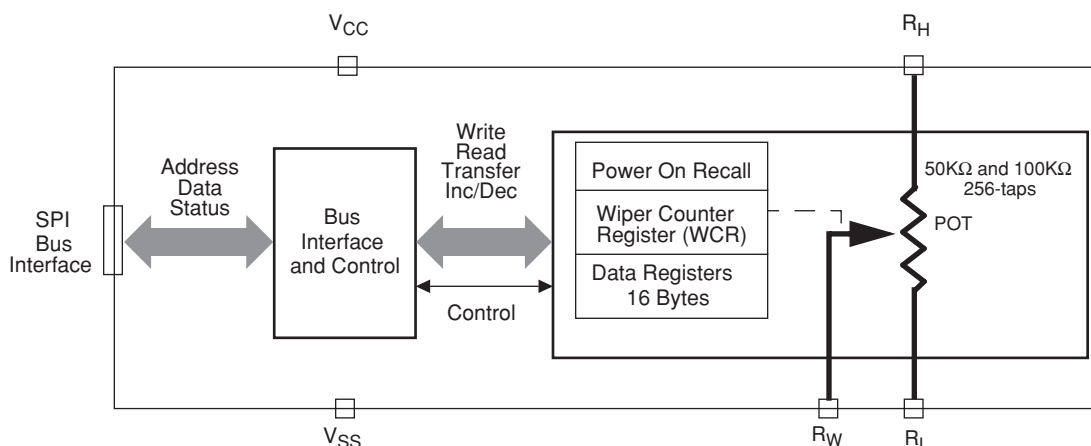

## DETAILED FUNCTIONAL DIAGRAM

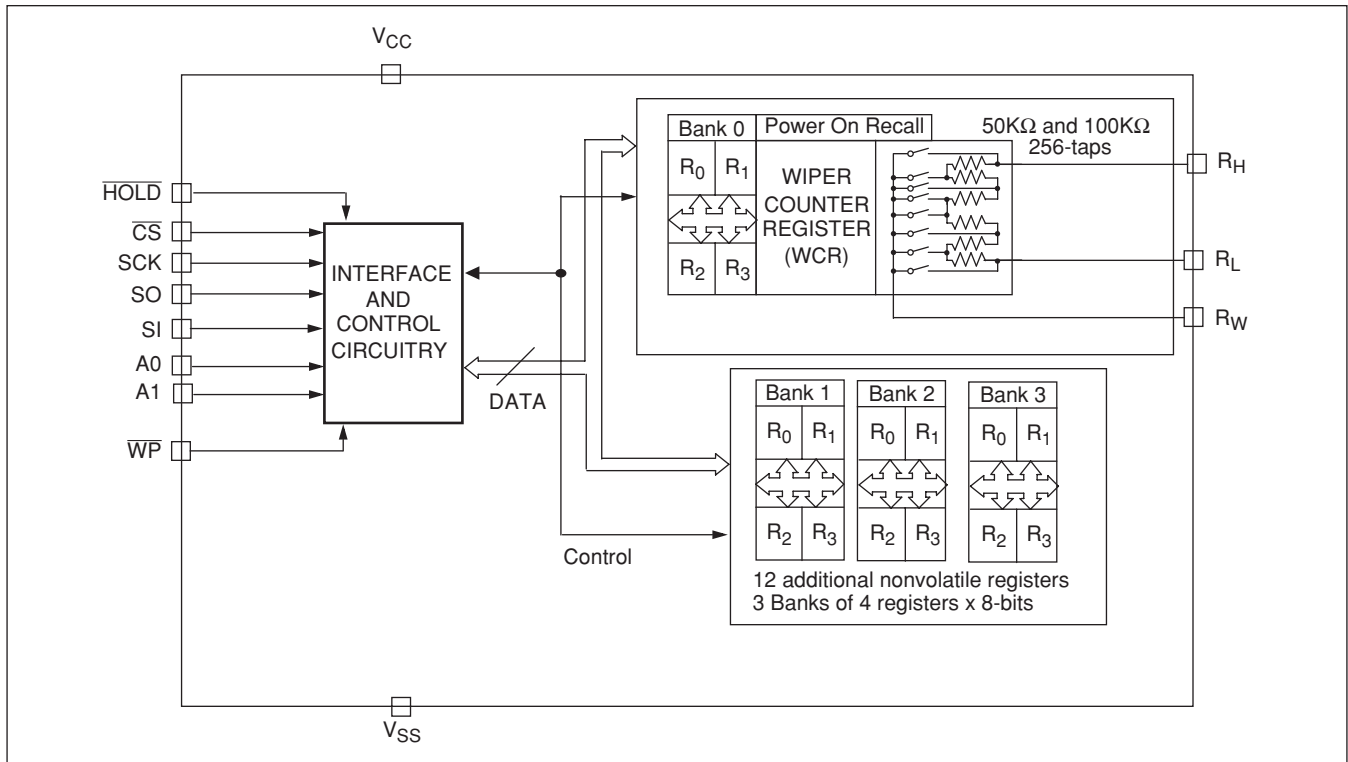

### CIRCUIT LEVEL APPLICATIONS

- Vary the gain of a voltage amplifier
- Provide programmable dc reference voltages for comparators and detectors
- Control the volume in audio circuits
- Trim out the offset voltage error in a voltage amplifier circuit
- Set the output voltage of a voltage regulator
- Trim the resistance in Wheatstone bridge circuits
- Control the gain, characteristic frequency and Q-factor in filter circuits
- Set the scale factor and zero point in sensor signal conditioning circuits
- Vary the frequency and duty cycle of timer ICs
- Vary the dc biasing of a pin diode attenuator in RF circuits
- Provide a control variable (I, V, or R) in feedback circuits

### SYSTEM LEVEL APPLICATIONS

- Adjust the contrast in LCD displays
- Control the power level of LED transmitters in communication systems
- Set and regulate the DC biasing point in an RF power amplifier in wireless systems
- Control the gain in audio and home entertainment systems
- Provide the variable DC bias for tuners in RF wireless systems
- Set the operating points in temperature control systems
- Control the operating point for sensors in industrial systems
- Trim offset and gain errors in artificial intelligent systems

# X9271

## PIN CONFIGURATION

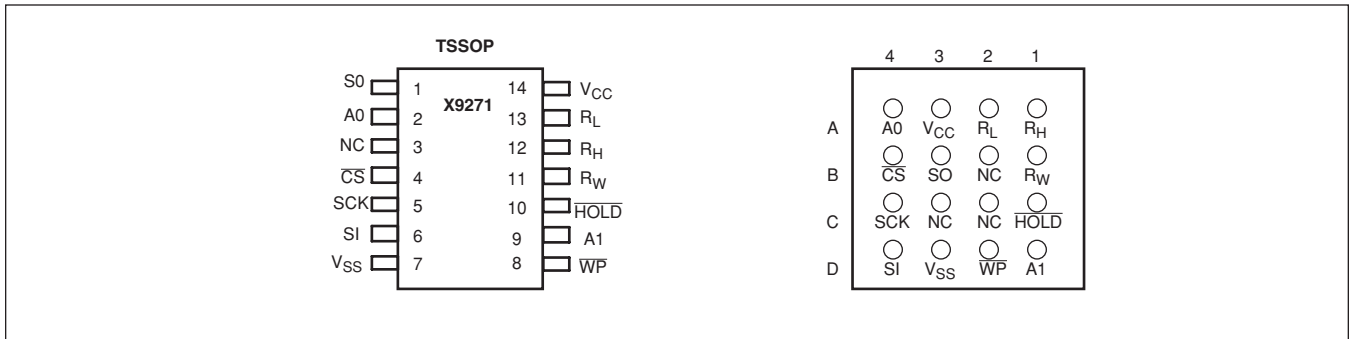

## PIN ASSIGNMENTS

TSSOP	CSP	Symbol	Function
1	B3	SO	Serial Data Output.
2	A4	A0	Device Address.
3	B2, C2, C3	NC	No Connect.
4	B4	$\overline{CS}$	Chip Select.
5	C4	SCK	Serial Clock.
6	D4	SI	Serial Data Input.
7	D3	VSS	System Ground.
8	D2	$\overline{WP}$	Hardware Write Protect.
9	D1	A1	Device Address.
10	C1	HOLD	Device select. Pause the serial bus.
11	B1	RW	Wiper Terminal of the Potentiometer.
12	A1	RH	High Terminal of the Potentiometer.
13	A2	RL	Low Terminal of the Potentiometer.
14	A3	VCC	System Supply Voltage.

# X9271

---

## PIN DESCRIPTIONS

### Bus Interface Pins

#### SERIAL OUTPUT (SO)

SO is a serial data output pin. During a read cycle, data is shifted out on this pin. Data is clocked out by the falling edge of the serial clock.

#### SERIAL INPUT

SI is the serial data input pin. All opcodes, byte addresses and data to be written to the pots and pot registers are input on this pin. Data is latched by the rising edge of the serial clock.

#### SERIAL CLOCK (SCK)

The SCK input is used to clock data into and out of the X9271.

#### HOLD ( $\overline{\text{HOLD}}$ )

$\overline{\text{HOLD}}$  is used in conjunction with the  $\overline{\text{CS}}$  pin to select the device. Once the part is selected and a serial sequence is underway,  $\overline{\text{HOLD}}$  may be used to pause the serial communication with the controller without resetting the serial sequence. To pause,  $\overline{\text{HOLD}}$  must be brought LOW while SCK is LOW. To resume communication,  $\overline{\text{HOLD}}$  is brought HIGH, again while SCK is LOW. If the pause feature is not used,  $\overline{\text{HOLD}}$  should be held HIGH at all times. CMOS level input.

#### DEVICE ADDRESS (A1 - A0)

The address inputs are used to set the the 8-bit slave address. A match in the slave address serial data stream must be made with the address input in order to initiate communication with the X9271.

#### CHIP SELECT ( $\overline{\text{CS}}$ )

When  $\overline{\text{CS}}$  is HIGH, the X9271 is deselected and the SO pin is at high impedance, and (unless an internal write cycle is underway) the device will be in the standby state.  $\overline{\text{CS}}$  LOW enables the X9271, placing it in the active power mode. It should be noted that after a power-up, a HIGH to LOW transition on  $\overline{\text{CS}}$  is required prior to the start of any operation.

### Potentiometer Pins

#### R<sub>H</sub>, R<sub>L</sub>

The R<sub>H</sub> and R<sub>L</sub> pins are equivalent to the terminal connections on a mechanical potentiometer.

#### R<sub>W</sub>

The wiper pin are equivalent to the wiper terminal of a mechanical potentiometer.

### Supply Pins

#### SYSTEM SUPPLY VOLTAGE (V<sub>CC</sub>) AND SUPPLY GROUND (V<sub>SS</sub>)

The V<sub>CC</sub> pin is the system supply voltage. The V<sub>SS</sub> pin is the system ground.

### Other Pins

#### HARDWARE WRITE PROTECT INPUT ( $\overline{\text{WP}}$ )

The  $\overline{\text{WP}}$  pin when LOW prevents nonvolatile writes to the Data Registers.

#### No CONNECT.

No connect pins should be left floating. This pins are used for Xicor manufacturing and testing purposes.

# X9271

## PRINCIPLES OF OPERATION

### Device Description

#### SERIAL INTERFACE

The X9271 supports the SPI interface hardware conventions. The device is accessed via the SI input with data clocked in on the rising SCK. CS must be LOW and the HOLD and WP pins must be HIGH during the entire operation.

The SO and SI pins can be connected together, since they have three state outputs. This can help to reduce system pin count.

#### ARRAY DESCRIPTION

The X9271 is comprised of a resistor array (see Figure 1). The array contains the equivalent of 255 discrete resistive segments that are connected in series. The

physical ends of each array are equivalent to the fixed terminals of a mechanical potentiometer ( $R_H$  and  $R_L$  inputs).

At both ends of each array and between each resistor segment is a CMOS switch connected to the wiper ( $R_W$ ) output. Within each individual array only one switch may be turned on at a time.

These switches are controlled by a Wiper Counter Register (WCR). The 8-bits of the WCR (WCR[7:0]) are decoded to select, and enable, one of 256 switches (see Table 1).

#### POWER UP AND DOWN RECOMMENDATIONS.

There are no restrictions on the power-up or power-down conditions of  $V_{CC}$  and the voltages applied to the potentiometer pins provided that  $V_{CC}$  is always more positive than or equal to  $V_H$ ,  $V_L$ , and  $V_W$ , i.e.,  $V_{CC} \geq V_H$ ,  $V_L$ ,  $V_W$ . The  $V_{CC}$  ramp rate specification is always in effect.

Figure 1. Detailed Potentiometer Block Diagram

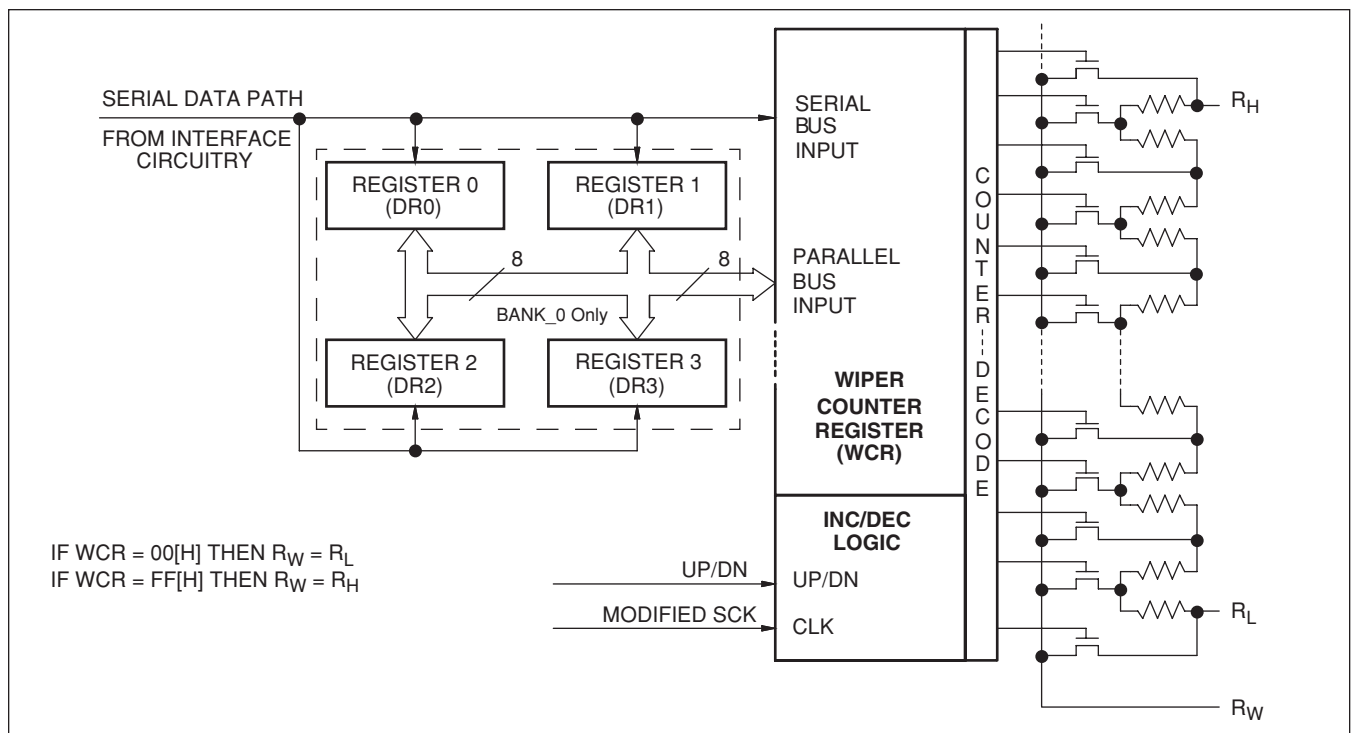

# X9271

## DEVICE DESCRIPTION

### Wiper Counter Register (WCR)

The X9271 contains a Wiper Counter Register for the DCP potentiometer. The Wiper Counter Register can be envisioned as a 8-bit parallel and serial load counter with its outputs decoded to select one of 256 switches along its resistor array. The contents of the WCR can be altered in four ways: it may be written directly by the host via the Write Wiper Counter Register instruction (serial load); it may be written indirectly by transferring the contents of one of four associated data registers via the XFR Data Register instruction (parallel load); it can be modified one step at a time by the Increment/ Decrement instruction. Finally, it is loaded with the contents of its Data Register zero (DR0) upon power-up.

The Wiper Counter Register is a volatile register; that is, its contents are lost when the X9271 is powered-down. Although the register is automatically loaded with the value in DR0 upon power-up, this may be different from the value present at power-down. Power-up guidelines are recommended to ensure proper loadings of the R0 value into the WCR. The DR0 value of Bank 0 is the default value.

### Data Registers (DR3–DR0)

The potentiometer has four 8-bit nonvolatile Data Registers. These can be read or written directly by the host. Data can also be transferred between any of the four Data Registers and the associated Wiper Counter Register. All operations changing data in one of the Data Registers is a nonvolatile operation and will take a maximum of 10ms.

If the application does not require storage of multiple settings for the potentiometer, the Data Registers can be used as regular memory locations for system parameters or user preference data.

Bits [7:0] are used to store one of the 256 wiper positions or data (0 ~255).

### Status Register (SR)

This 1-bit Status Register is used to store the system status.

WIP: Write In Progress status bit, read only.

- When WIP=1, indicates that high-voltage write cycle is in progress.
- When WIP=0, indicates that no high-voltage write cycle is in progress

**Table 1. Wiper counter Register, WCR (8-bit), WCR[7:0]:** Used to store the current wiper position (Volatile, V).

WCR7	WCR6	WCR5	WCR4	WCR3	WCR2	WCR1	WCR0
V	V	V	V	V	V	V	V
(MSB)							(LSB)

**Table 2. Data Register, DR (8-bit), DR[7:0]:** Used to store wiper positions or data (Nonvolatile, NV).

Bit 7	Bit 6	Bit 5	Bit 4	Bit 3	Bit 2	Bit 1	Bit 0
NV	NV	NV	NV	NV	NV	NV	NV
MSB							LSB

**Table 3. Status Register, SR (WIP is 1-bit)**

WIP
(LSB)

# X9271

## DEVICE DESCRIPTION

### Instructions

#### IDENTIFICATION BYTE (ID AND A)

The first byte sent to the X9271 from the host, following a CS going HIGH to LOW, is called the Identification byte. The most significant four bits of the slave address are a device type identifier. The ID[3:0] bits is the device id for the X9271; this is fixed as 0101[B] (refer to Table 4).

The A1-A0 bits in the ID byte is the internal slave address. The physical device address is defined by the state of the A1-A0 input pins. The slave address is externally specified by the user. The X9271 compares the serial data stream with the address input state; a successful compare of both address bits is required for the X9271 to successfully continue the command sequence. Only the device which slave address matches the incoming device address sent by the master executes the instruction. The A1-A0 inputs can be actively driven by CMOS input signals or tied to  $V_{CC}$  or  $V_{SS}$ .

#### INSTRUCTION BYTE (I[3:0])

The next byte sent to the X9271 contains the instruction and register pointer information. The three most significant bits are used provide the instruction opcode (I[3:0]). The RB and RA bits point to one of the four Data Registers. P0 is the POT selection; since the X9271 is single POT, the P0=0. The format is shown in Table 5.

#### REGISTER BANK SELECTION (R1, R0, P1, P0)

There are 16 registers organized into four banks. Bank 0 is the default bank of registers. Only Bank 0 registers can be used for data register to Wiper Counter Register operations.

Banks 1, 2, and 3 are additional banks of registers (12 total) that can be used for SPI write and read operations. The data registers in Banks 1, 2, and 3 cannot be used for direct read/write operations between the Wiper Counter Register.

#### Register Selection (DR0 to DR3) Table

RB	RA	Register Selection	Operations
0	0	0	Data Register Read and Write; Wiper Counter Register Operations
0	1	1	Data Register Read and Write; Wiper Counter Register Operations
1	0	2	Data Register Read and Write; Wiper Counter Register Operations
1	1	3	Data Register Read and Write; Wiper Counter Register Operations

#### Register Bank Selection (Bank 0 to Bank 3) Table

P1	P0	Bank Selection	Operations
0	0	0	Data Register Read and Write; Wiper Counter Register Operations
0	1	1	Data Register Read and Write Only
1	0	2	Data Register Read and Write Only
1	1	3	Data Register Read and Write Only

**Table 4. Identification Byte Format**

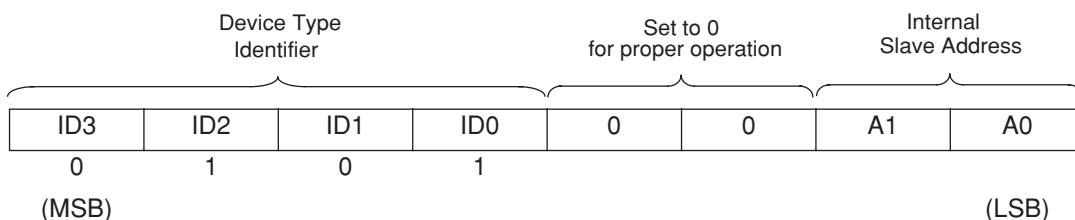

**Table 5. Instruction Byte Format**

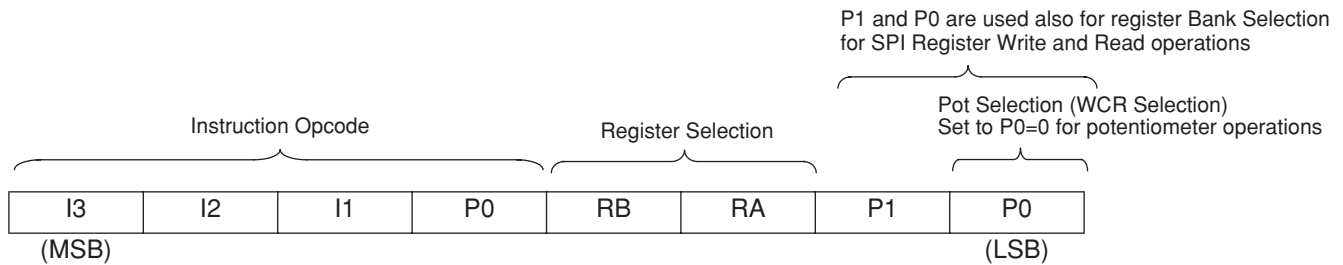

## DEVICE DESCRIPTION

### Instructions

Five of the eight instructions are three bytes in length. These instructions are:

- **Read Wiper Counter Register** – read the current wiper position of the potentiometer;
- **Write Wiper Counter Register** – change current wiper position of the potentiometer;
- **Read Data Register** – read the contents of the selected Data Register;
- **Write Data Register** – write a new value to the selected Data Register.
- **Read Status** - This command returns the contents of the WIP bit which indicates if the internal write cycle is in progress.

The basic sequence of the three byte instructions is illustrated in Figure 3. These three-byte instructions exchange data between the WCR and one of the Data Registers. A transfer from a Data Register to a WCR is essentially a write to a static RAM, with the static RAM controlling the wiper position. The response of the wiper to this action will be delayed by  $t_{WRL}$ . A transfer from the WCR (current wiper position), to a Data Register is a write to nonvolatile memory and takes a minimum of  $t_{WR}$  to complete. The transfer can occur between one of the four potentiometers and one of its associated registers; or it may occur globally, where the transfer occurs between all potentiometers and one associated register. The Read Status Register instruction is the only unique format (see Figure 4).

Two instructions require a two-byte sequence to complete (Figure 2). These instructions transfer data between the host and the X9271; either between the host and one of the data registers or directly between the host and the Wiper Counter Register. These instructions are:

- **XFR Data Register to Wiper Counter Register** – This transfers the contents of one specified Data Register to the associated Wiper Counter Register.
- **XFR Wiper Counter Register to Data Register** – This transfers the contents of the specified Wiper Counter Register to the specified associated Data Register.

The final command is Increment/Decrement (Figure 5 and 6). It is different from the other commands, because it's length is indeterminate. Once the command is issued, the master can clock the selected wiper up and/or down in one resistor segment steps; thereby, providing a fine tuning capability to the host. For each SCK clock pulse ( $t_{HIGH}$ ) while SI is HIGH, the selected wiper will move one resistor segment towards the  $R_H$  terminal. Similarly, for each SCK clock pulse while SI is LOW, the selected wiper will move one resistor segment towards the  $R_L$  terminal.

See Instruction format for more details.

### Write in Process (WIP bit)

The contents of the Data Registers are saved to nonvolatile memory when the  $\overline{CS}$  pin goes from LOW to HIGH after a complete write sequence is received by the device. The progress of this internal write operation can be monitored by a Write In Process bit (WIP). The WIP bit is read with a Read Status command.



Figure 2. Two-Byte Instruction Sequence

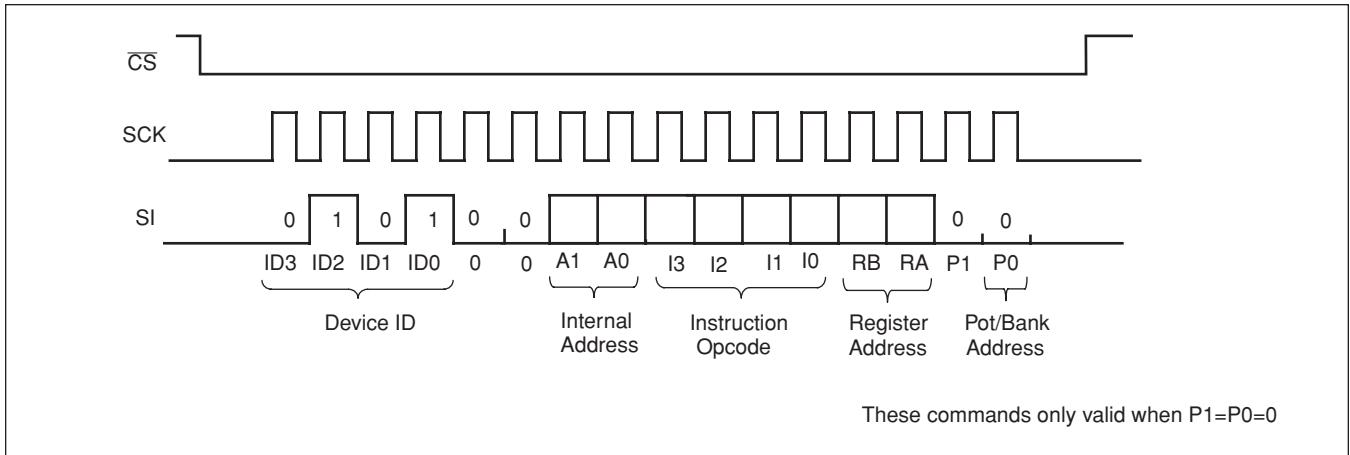

Figure 3. Three-Byte Instruction Sequence (Write)

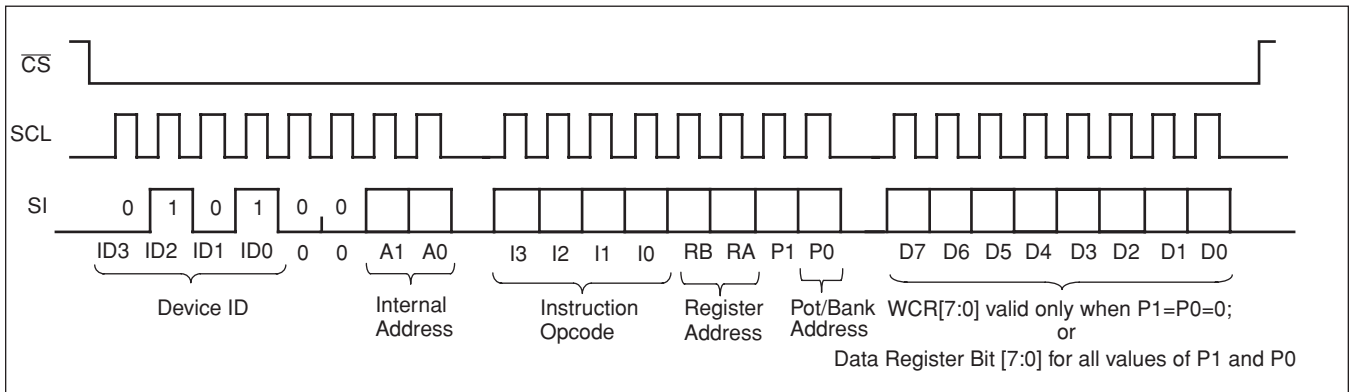

Figure 4. Three-Byte Instruction Sequence (Read)

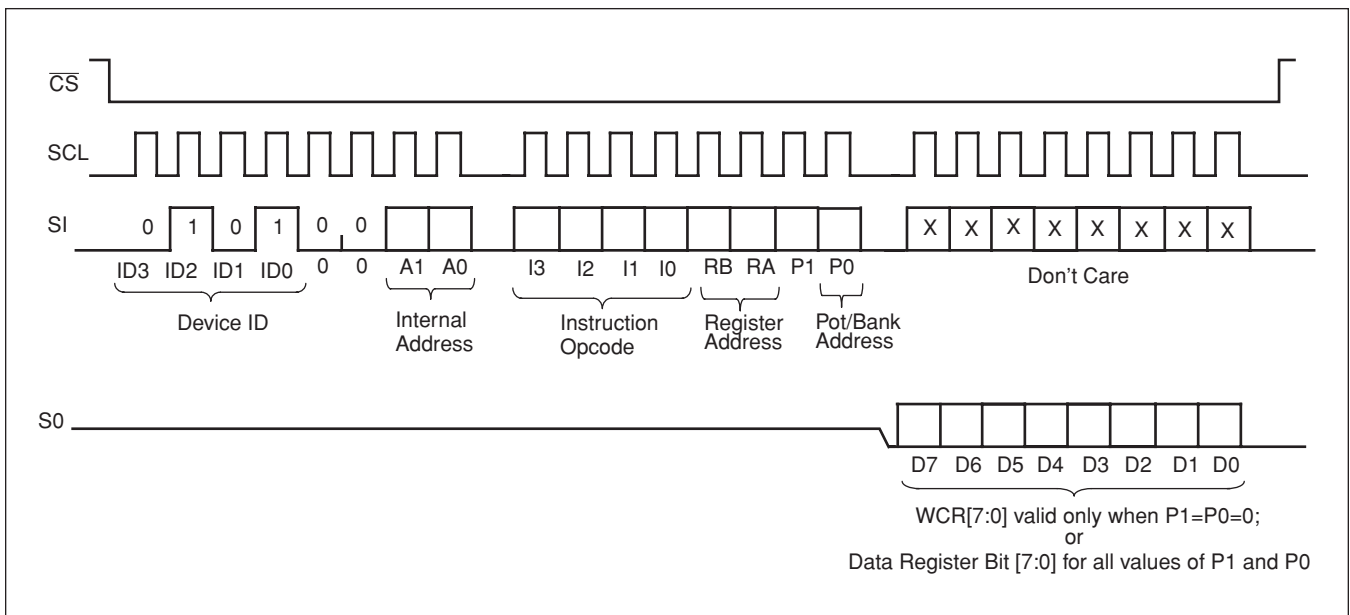

Figure 5. Increment/Decrement Instruction Sequence

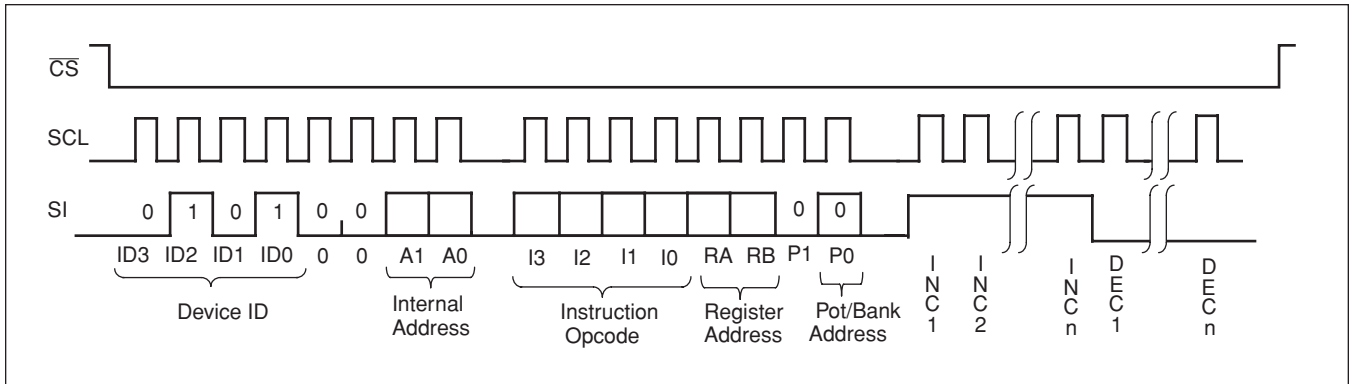

Figure 6. Increment/Decrement Timing Limits

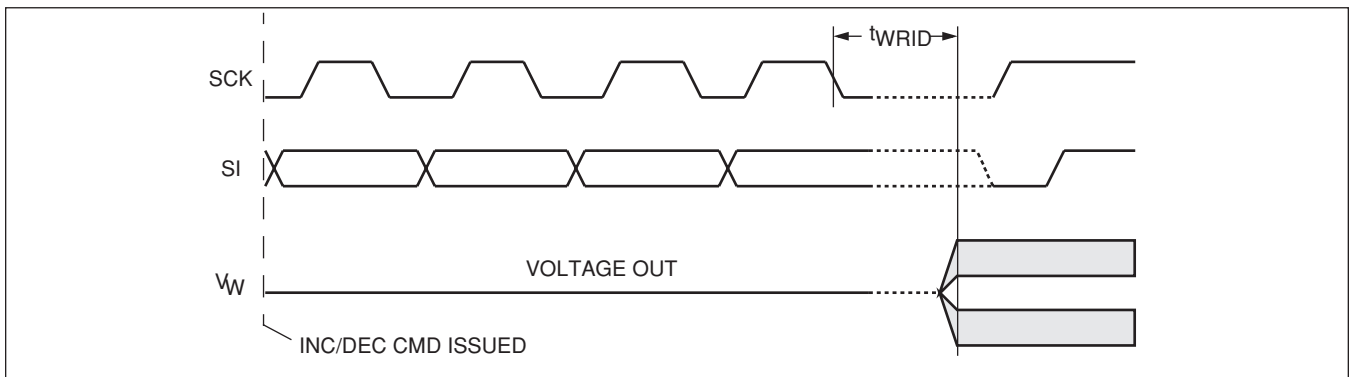

Table 6. Instruction Set

Instruction	Instruction Set								Operation
	I3	I2	I1	I0	RB	RA	P <sub>1</sub>	P <sub>0</sub>	
Read Wiper Counter Register	1	0	0	1	0	0	0	1/0	Read the contents of the Wiper Counter Register
Write Wiper Counter Register	1	0	1	0	0	0	0	1/0	Write new value to the Wiper Counter Register
Read Data Register	1	0	1	1	1/0	1/0	1/0	1/0	Read the contents of the Data Register pointed to by P1-P0 and RB-RA
Write Data Register	1	1	0	0	1/0	1/0	1/0	1/0	Write new value to the Data Register pointed to by P1-P0 and RB-RA
XFR Data Register to Wiper Counter Register	1	1	0	1	1/0	1/0	0	0	Transfer the contents of the Data Register pointed to by RB-RA (Bank 0 only) to the Wiper Counter Register
XFR Wiper Counter Register to Data Register	1	1	1	0	1/0	1/0	0	0	Transfer the contents of the Wiper Counter Register to the Register pointed to by RB-RA (Bank 0 only)
Increment/Decrement Wiper Counter Register	0	0	1	0	0	0	0	0	Enable Increment/decrement of the Wiper Counter Register
Read Status (WIP bit)	0	1	0	1	0	0	0	1	Read the status of the internal write cycle, by checking the WIP bit.

Note: 1/0 = data is one or zero

# X9271

## INSTRUCTION FORMAT

### Read Wiper Counter Register (WCR)

$\overline{\text{CS}}$ Falling Edge	Device Type Identifier				Device Addresses				Instruction Opcode				DR/Bank Addresses				Wiper Position (Sent by X9271 on SO)								$\overline{\text{CS}}$ Rising Edge
	0	1	0	1	0	0	A1	A0	1	0	0	1	0	0	0	0	W C R 7	W C R 6	W C R 5	W C R 4	W C R 3	W C R 2	W C R 1	W C R 0	
	0	1	0	1	0	0	A1	A0	1	0	0	1	0	0	0	0									

### Write Wiper Counter Register (WCR)

$\overline{\text{CS}}$ Falling Edge	Device Type Identifier				Device Addresses				Instruction Opcode				DR/Bank Addresses				Data Byte (Sent by Host on SI)								$\overline{\text{CS}}$ Rising Edge
	0	1	0	1	0	0	A1	A0	1	0	1	0	0	0	0	0	W C R 7	W C R 6	W C R 5	W C R 4	W C R 3	W C R 2	W C R 1	W C R 0	
	0	1	0	1	0	0	A1	A0	1	0	1	0	0	0	0	0									

### Read Data Register (DR)

$\overline{\text{CS}}$ Falling Edge	Device Type Identifier				Device Addresses				Instruction Opcode				DR/Bank Addresses				Data Byte (Sent by X9271 on SO)								$\overline{\text{CS}}$ Rising Edge
	0	1	0	1	0	0	A1	A0	1	0	1	1	RB	RA	P1	P0	D7	D6	D5	D4	D3	D2	D1	D0	
	0	1	0	1	0	0	A1	A0	1	0	1	1	RB	RA	P1	P0	D7	D6	D5	D4	D3	D2	D1	D0	

### Write Data Register (DR)

$\overline{\text{CS}}$ Falling Edge	Device Type Identifier				Device Addresses				Instruction Opcode				DR/Bank Addresses				Data Byte (Sent by Host on SI)								$\overline{\text{CS}}$ Rising Edge	HIGH-VOLTAGE WRITE CYCLE
	0	1	0	1	0	0	A1	A0	1	1	0	0	RB	RA	P1	P0	D7	D6	D5	D4	D3	D2	D1	D0		
	0	1	0	1	0	0	A1	A0	1	1	0	0	RB	RA	P1	P0	D7	D6	D5	D4	D3	D2	D1	D0		

### Transfer Wiper Counter Register (WCR) to Data Register (DR)

$\overline{\text{CS}}$ Falling Edge	Device Type Identifier				Device Addresses				Instruction Opcode				DR/Bank Addresses				$\overline{\text{CS}}$ Rising Edge	HIGH-VOLTAGE WRITE CYCLE
	0	1	0	1	0	0	A1	A0	1	1	1	0	RB	RA	0	0		
	0	1	0	1	0	0	A1	A0	1	1	1	0	RB	RA	0	0		

# X9271

## Transfer Data Register (DR) to Wiper Counter Register (WCR)

$\overline{CS}$ Falling Edge	Device Type Identifier				Device Addresses				Instruction Opcode				DR/Bank Addresses				$\overline{CS}$ Rising Edge
	0	1	0	1	0	0	A1	A0	1	1	0	1	RB	RA	0	0	

## Increment/Decrement Wiper Counter Register (WCR)

$\overline{CS}$ Falling Edge	Device Type Identifier				Device Addresses				Instruction Opcode				DR/Bank Addresses				Increment/Decrement (Sent by Master on SDA)				$\overline{CS}$ Rising Edge		
	0	1	0	1	0	0	A1	A0	0	0	1	0	X	X	0	0	I/D	I/D	.	.		.	.

## Read Status Register (SR)

$\overline{CS}$ Falling Edge	Device Type Identifier				Device Addresses				Instruction Opcode				DR/Bank Addresses				Data Byte (Sent by X9271 on SO)								$\overline{CS}$ Rising Edge							
	0	1	0	1	0	0	A1	A0	0	1	0	1	0	0	0	1	0	0	0	0	0	0	0	0		0	0	0	0	0	0	0

- Notes:** (1) "A1 ~ A0": stands for the device addresses sent by the master.  
 (2) WCRx refers to wiper position data in the Wiper Counter Register  
 (3) "I": stands for the increment operation, SI held HIGH during active SCK phase (high).  
 (4) "D": stands for the decrement operation, SI held LOW during active SCK phase (high).  
 (5) "X": Don't Care.

# X9271

## ABSOLUTE MAXIMUM RATINGS

Temperature under bias .....-65°C to +135°C  
 Storage temperature .....-65°C to +150°C  
 Voltage on SCK any address input  
 with respect to  $V_{SS}$ .....-1V to +7V  
 $\Delta V = |(V_H - V_L)|$ ..... 5.5V  
 Lead temperature (soldering, 10 seconds)..... 300°C  
 $I_W$  (10 seconds).....  $\pm 6$ mA

## COMMENT

Stresses above those listed under “Absolute Maximum Ratings” may cause permanent damage to the device. This is a stress rating only; the functional operation of the device (at these or any other conditions above those listed in the operational sections of this specification) is not implied. Exposure to absolute maximum rating conditions for extended periods may affect device reliability.

## RECOMMENDED OPERATING CONDITIONS

Temp	Min.	Max.
Commercial	0°C	+70°C
Industrial	-40°C	+85°C

Device	Supply Voltage ( $V_{CC}$ ) <sup>(4)</sup> Limits
X9271	5V $\pm$ 10%
X9271-2.7	2.7V to 5.5V

## ANALOG CHARACTERISTICS (Over recommended industrial operating conditions unless otherwise stated.)

Symbol	Parameter	Limits				Test Conditions
		Min.	Typ.	Max.	Units	
$R_{TOTAL}$	End to End Resistance		100		k $\Omega$	T version
$R_{TOTAL}$	End to End Resistance		50		k $\Omega$	U version
	End to End Resistance Tolerance			$\pm 20$	%	
	Power Rating			50	mW	25°C, each pot
$I_W$	Wiper Current			$\pm 3$	mA	
$R_W$	Wiper Resistance			300	$\Omega$	$I_W = \pm 3$ mA @ $V_{CC} = 3$ V
$R_W$	Wiper Resistance			150	$\Omega$	$I_W = \pm 3$ mA @ $V_{CC} = 5$ V
$V_{TERM}$	Voltage on any $R_H$ or $R_L$ Pin	$V_{SS}$		$V_{CC}$	V	$V_{SS} = 0$ V
	Noise		-120		dBV/ $\sqrt{Hz}$	Ref: 1V
	Resolution		0.4		%	
	Absolute Linearity <sup>(1)</sup>			$\pm 1$	MI <sup>(3)</sup>	$R_{W(n)(actual)} - R_{W(n)(expected)}$ <sup>(5)</sup>
	Relative Linearity <sup>(2)</sup>			$\pm 0.2$	MI <sup>(3)</sup>	$R_{W(n+1)} - [R_{W(n)} + MI]$ <sup>(5)</sup>
	Temperature Coefficient of $R_{TOTAL}$		$\pm 300$		ppm/°C	
	Ratiometric Temp. Coefficient			20	ppm/°C	
$C_H/C_L/C_W$	Potentiometer Capacitancies		10/10/25		pF	See Macro model

- Notes:** (1) Absolute linearity is utilized to determine actual wiper voltage versus expected voltage as determined by wiper position when used as a potentiometer.  
 (2) Relative linearity is utilized to determine the actual change in voltage between two successive tap positions when used as a potentiometer. It is a measure of the error in step size.  
 (3)  $MI = RTOT / 255$  or  $(R_H - R_L) / 255$ , single pot  
 (4) During power up  $V_{CC} > V_H, V_L$ , and  $V_W$ .  
 (5)  $n = 0, 1, 2, \dots, 255$ ;  $m = 0, 1, 2, \dots, 254$ .

# X9271

## D.C. OPERATING CHARACTERISTICS (Over the recommended operating conditions unless otherwise specified.)

Symbol	Parameter	Limits				Test Conditions
		Min.	Typ.	Max.	Units	
I <sub>CC1</sub>	V <sub>CC</sub> supply current (active)			400	μA	f <sub>SCK</sub> = 2.5 MHz, SO = Open, V <sub>CC</sub> =6V Other Inputs = V <sub>SS</sub>
I <sub>CC2</sub>	V <sub>CC</sub> supply current (nonvolatile write)		1	5	mA	f <sub>SCK</sub> = 2.5MHz, SO = Open, V <sub>CC</sub> =6V Other Inputs = V <sub>SS</sub>
I <sub>SB</sub>	V <sub>CC</sub> current (standby)			3	μA	SCK = SI = V <sub>SS</sub> , Addr. = V <sub>SS</sub> , CS = V <sub>CC</sub> = 6V
I <sub>LI</sub>	Input leakage current			10	μA	V <sub>IN</sub> = V <sub>SS</sub> to V <sub>CC</sub>
I <sub>LO</sub>	Output leakage current			10	μA	V <sub>OUT</sub> = V <sub>SS</sub> to V <sub>CC</sub>
V <sub>IH</sub>	Input HIGH voltage	V <sub>CC</sub> × 0.7		V <sub>CC</sub> + 1	V	
V <sub>IL</sub>	Input LOW voltage	-1		V <sub>CC</sub> × 0.3	V	
V <sub>OL</sub>	Output LOW voltage			0.4	V	I <sub>OL</sub> = 3mA
V <sub>OH</sub>	Output HIGH voltage	V <sub>CC</sub> - 0.8			V	I <sub>OH</sub> = -1mA, V <sub>CC</sub> ≥ +3V
V <sub>OH</sub>	Output HIGH voltage	V <sub>CC</sub> - 0.4			V	I <sub>OH</sub> = -0.4mA, V <sub>CC</sub> ≤ +3V

## ENDURANCE AND DATA RETENTION

Parameter	Min.	Units
Minimum endurance	100,000	Data changes per bit per register
Data retention	100	years

## CAPACITANCE

Symbol	Test	Max.	Units	Test Conditions
C <sub>IN/OUT</sub> <sup>(6)</sup>	Input / Output capacitance (SI)	8	pF	V <sub>OUT</sub> = 0V
C <sub>OUT</sub> <sup>(6)</sup>	Output capacitance (SO)	8	pF	V <sub>OUT</sub> = 0V
C <sub>IN</sub> <sup>(6)</sup>	Input capacitance (A0, CS, WP, HOLD, and SCK)	6	pF	V <sub>IN</sub> = 0V

## POWER-UP TIMING

Symbol	Parameter	Min.	Max.	Units
t <sub>r</sub> V <sub>CC</sub> <sup>(6)</sup>	V <sub>CC</sub> Power-up rate	0.2	50	V/ms
t <sub>PUR</sub> <sup>(7)</sup>	Power-up to initiation of read operation		1	ms
t <sub>PUW</sub> <sup>(7)</sup>	Power-up to initiation of write operation		50	ms

## A.C. TEST CONDITIONS

Input Pulse Levels	V <sub>CC</sub> × 0.1 to V <sub>CC</sub> × 0.9
Input rise and fall times	10ns
Input and output timing level	V <sub>CC</sub> × 0.5

**Notes:** (6) This parameter is not 100% tested

(7) t<sub>PUR</sub> and t<sub>PUW</sub> are the delays required from the time the (last) power supply (V<sub>CC</sub>) is stable until the specific instruction can be issued. These parameters are periodically sampled and not 100% tested.

# X9271

## EQUIVALENT A.C. LOAD CIRCUIT

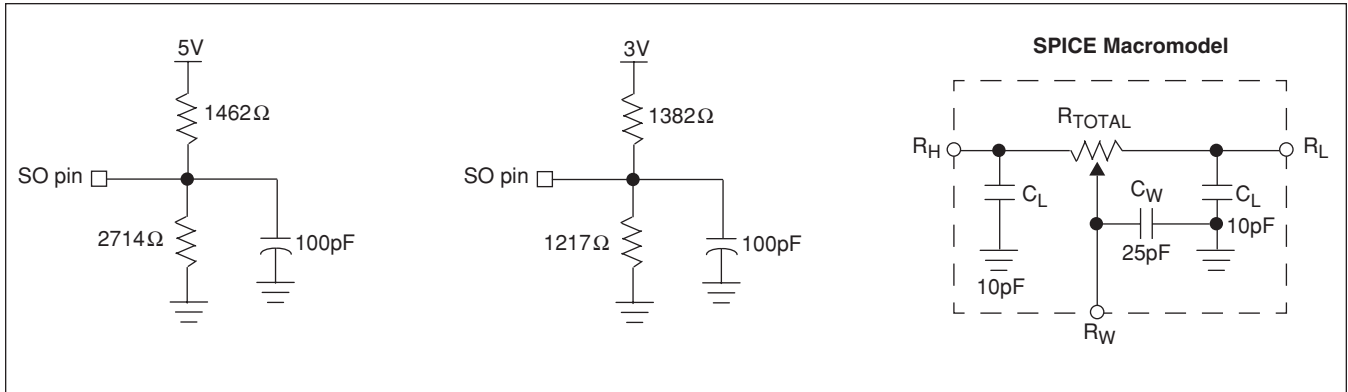

## AC TIMING

Symbol	Parameter	Min.	Max.	Units
$f_{SCK}$	SSI/SPI clock frequency		2.5	MHz
$t_{CYC}$	SSI/SPI clock cycle time	500		ns
$t_{WH}$	SSI/SPI clock high time	200		ns
$t_{WL}$	SSI/SPI clock low time	200		ns
$t_{LEAD}$	Lead time	250		ns
$t_{LAG}$	Lag time	250		ns
$t_{SU}$	SI, SCK, $\overline{HOLD}$ and $\overline{CS}$ input setup time	50		ns
$t_H$	SI, SCK, $\overline{HOLD}$ and $\overline{CS}$ input hold time	50		ns
$t_{RI}$	SI, SCK, $\overline{HOLD}$ and $\overline{CS}$ input rise time		2	$\mu s$
$t_{FI}$	SI, SCK, $\overline{HOLD}$ and $\overline{CS}$ input fall time		2	$\mu s$
$t_{DIS}$	SO output disable time	0	250	ns
$t_V$	SO output valid time		200	ns
$t_{HO}$	SO output hold time	0		ns
$t_{RO}$	SO output rise time		100	ns
$t_{FO}$	SO output fall time		100	ns
$t_{HOLD}$	$\overline{HOLD}$ time	400		ns
$t_{HSU}$	$\overline{HOLD}$ setup time	100		ns
$t_{HH}$	$\overline{HOLD}$ hold time	100		ns
$t_{HZ}$	$\overline{HOLD}$ low to output in high Z		100	ns
$t_{LZ}$	$\overline{HOLD}$ high to output in low Z		100	ns
$T_I$	Noise suppression time constant at SI, SCK, $\overline{HOLD}$ and $\overline{CS}$ inputs		10	ns
$t_{CS}$	$\overline{CS}$ deselect time	2		$\mu s$
$t_{WPASU}$	$\overline{WP}$ , A0 setup time	0		ns
$t_{WPAH}$	$\overline{WP}$ , A0 hold time	0		ns

# X9271



## HIGH-VOLTAGE WRITE CYCLE TIMING

Symbol	Parameter	Typ.	Max.	Units
$t_{WR}$	High-voltage write cycle time (store instructions)	5	10	ms

## XDCP TIMING

Symbol	Parameter	Min.	Max.	Units
$t_{WRPO}$	Wiper response time after the third (last) power supply is stable	5	10	$\mu$ s
$t_{WRL}$	Wiper response time after instruction issued (all load instructions)	5	10	$\mu$ s

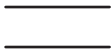
## SYMBOL TABLE

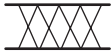
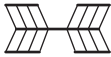
WAVEFORM	INPUTS	OUTPUTS
	Must be steady	Will be steady
	May change from Low to High	Will change from Low to High
	May change from High to Low	Will change from High to Low
	Don't Care: Changes Allowed	Changing: State Not Known
	N/A	Center Line is High Impedance



# X9271

## TIMING DIAGRAMS

### Input Timing

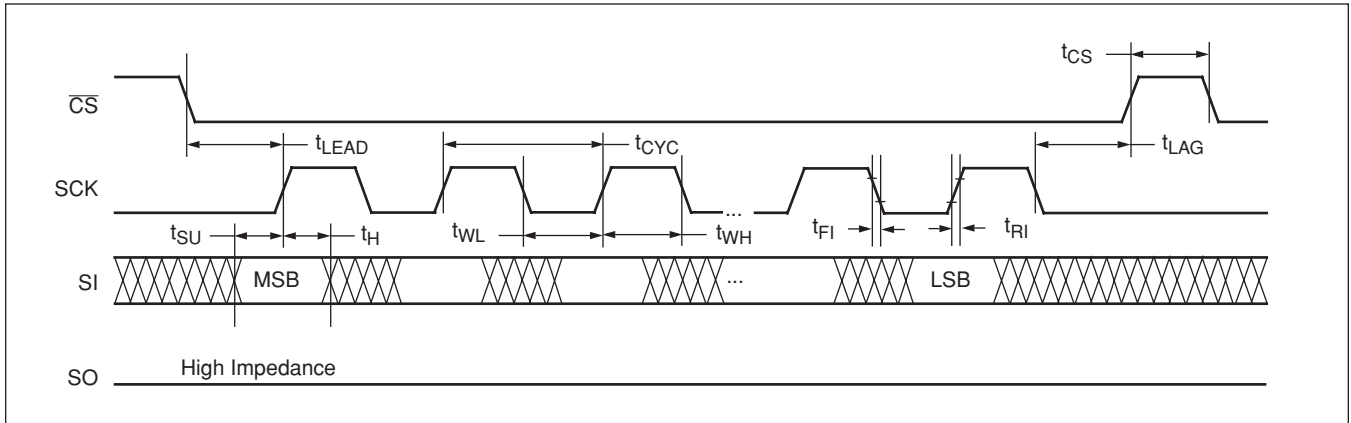

### Output Timing

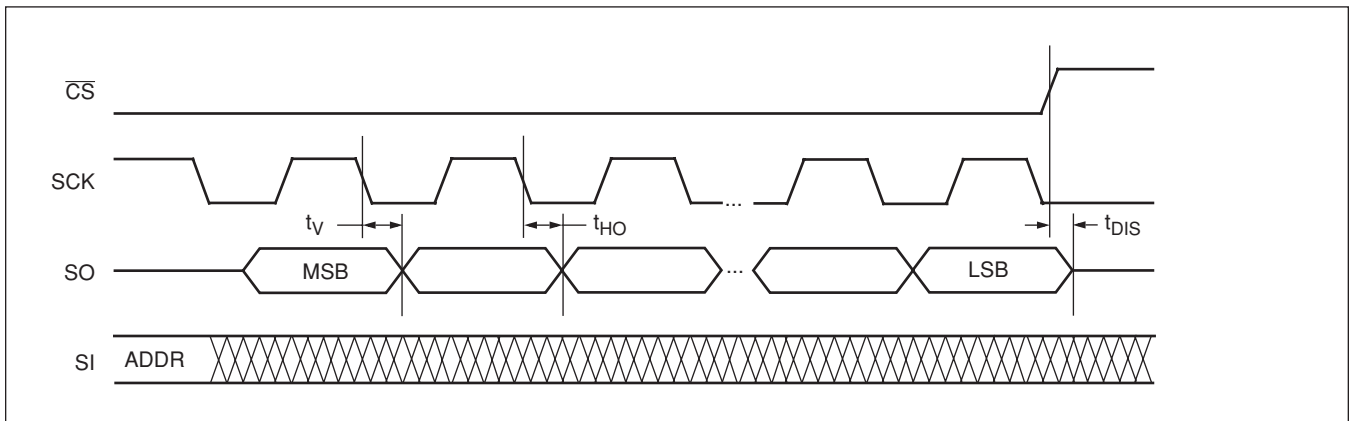

### Hold Timing

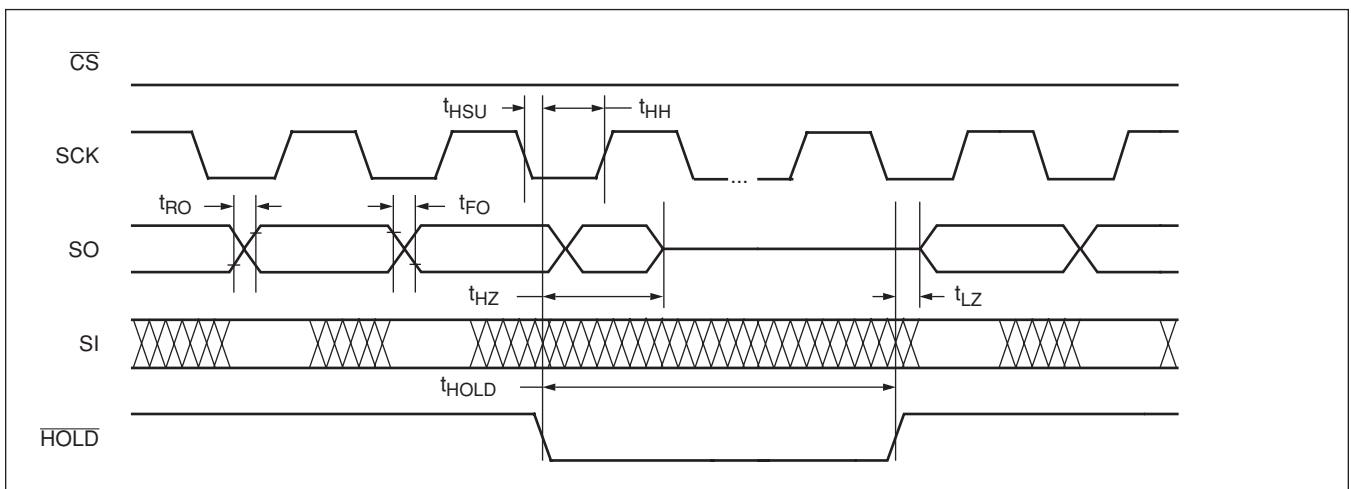

# X9271

## XDCP Timing (for All Load Instructions)

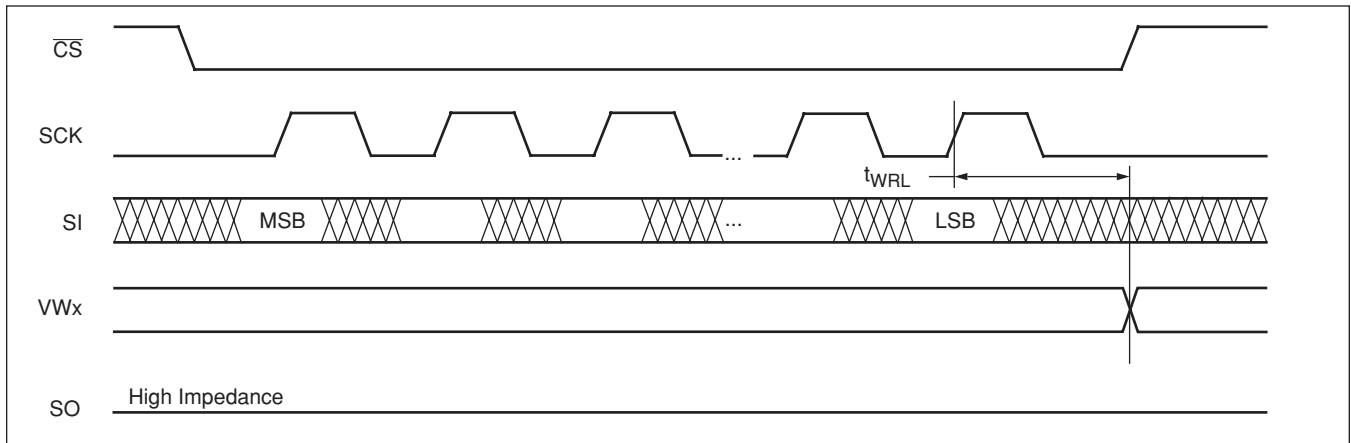

## Write Protect and Device Address Pins Timing

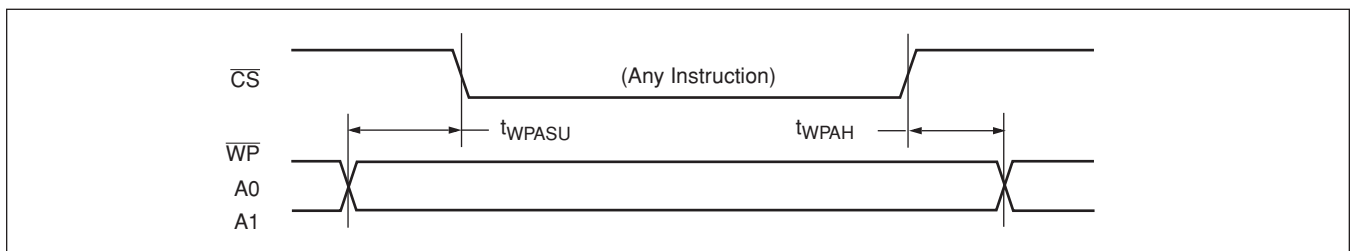

APPLICATIONS INFORMATION

Basic Configurations of Electronic Potentiometers

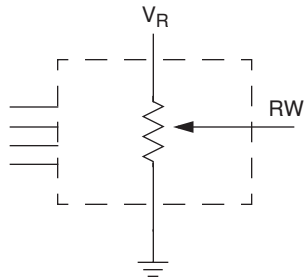

Three terminal Potentiometer;  
Variable voltage divider

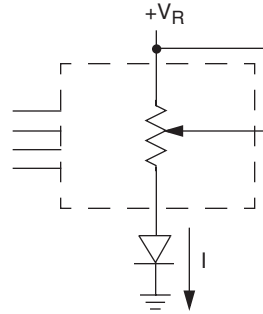

Two terminal Variable Resistor;  
Variable current

Application Circuits

Noninverting Amplifier

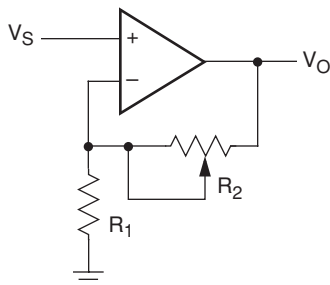

$$V_O = (1 + R_2/R_1)V_S$$

Voltage Regulator

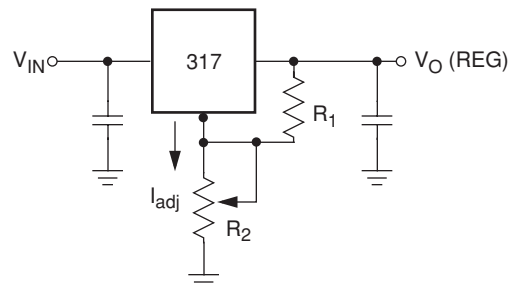

$$V_O (REG) = 1.25V (1 + R_2/R_1) + I_{adj} R_2$$

Offset Voltage Adjustment

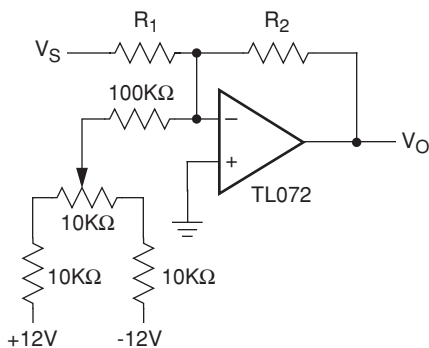

Comparator with Hysteresis

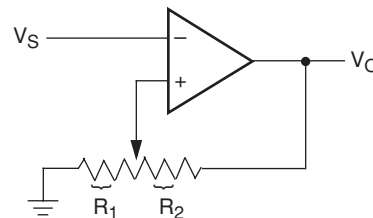

$$V_{UL} = \{R_1/(R_1 + R_2)\} V_O(\max)$$

$$V_{LL} = \{R_1/(R_1 + R_2)\} V_O(\min)$$

Application Circuits (continued)

Attenuator

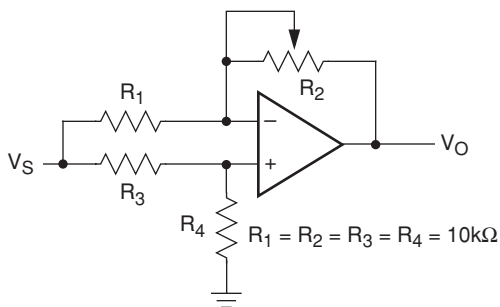

$$V_O = G V_S$$

$$-1/2 \leq G \leq +1/2$$

Filter

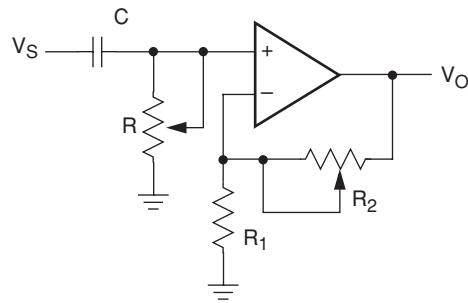

$$G_O = 1 + R_2/R_1$$

$$f_c = 1/(2\pi RC)$$

Inverting Amplifier

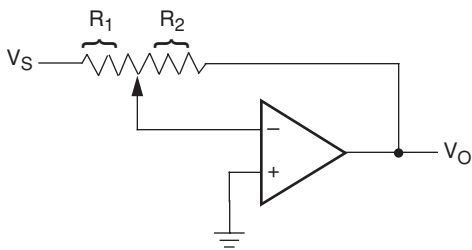

$$V_O = G V_S$$

$$G = -R_2/R_1$$

Equivalent L-R Circuit

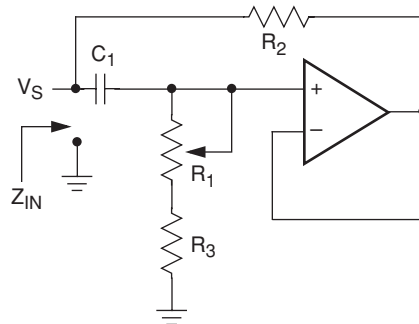

$$Z_{IN} = R_2 + s R_2 (R_1 + R_3) C_1 = R_2 + s L_{eq}$$

$$(R_1 + R_3) \gg R_2$$

Function Generator

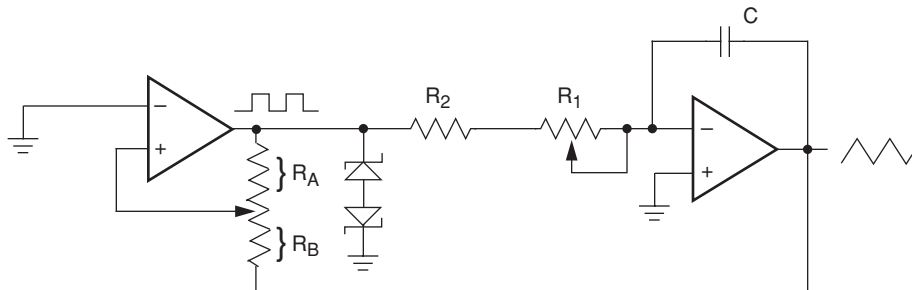

$$\text{frequency} \propto R_1, R_2, C$$

$$\text{amplitude} \propto R_A, R_B$$

# X9271

## PACKAGING INFORMATION

### 14-LEAD PLASTIC, TSSOP, PACKAGE TYPE V

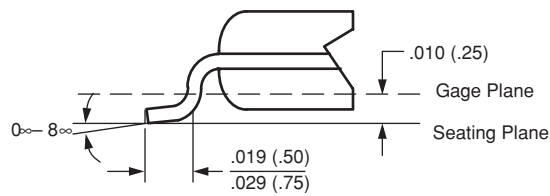
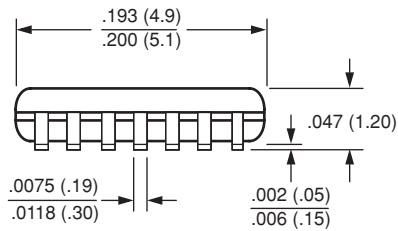
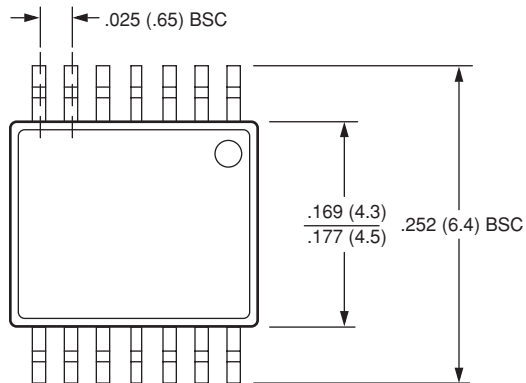

Detail A (20X)

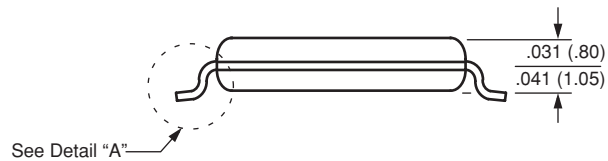

See Detail "A"

NOTE: ALL DIMENSIONS IN INCHES (IN PARENTHESES IN MILLIMETERS)

# X9271

## 16-Bump Chip Scale Package (CSP B16) Package Outline Drawing

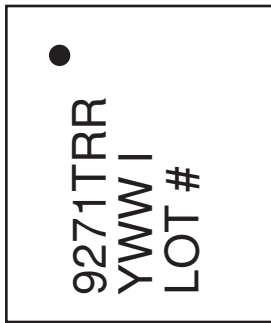

Top View (Marking Side)

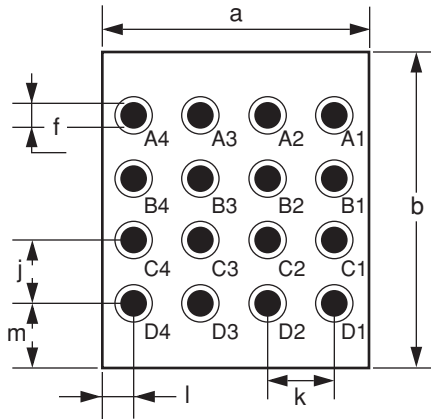

Bottom View (Bumped Side)

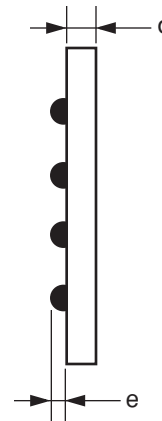

Side View



Side View

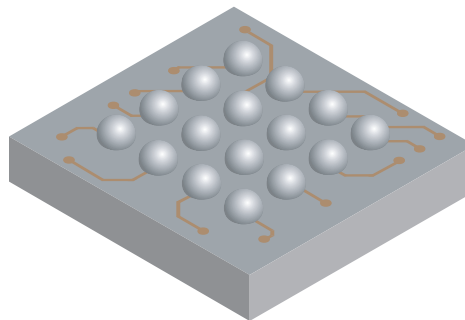

### Package Dimensions

	Symbol	Millimeters		
		Min	Nominal	Max
Package Width	a	2.593	2.623	2.653
Package Length	b	2.771	2.801	2.831
Package Height	c	0.644	0.677	0.710
Body Thickness	d	0.444	0.457	0.470
Ball Height	e	0.200	0.220	0.240
Ball Diameter	f	0.300	0.320	0.340
Ball Pitch – Width	j		0.5	
Ball Pitch – Length	k		0.5	
Ball to Edge Spacing – Width	l	0.537	0.562	0.587
Ball to Edge Spacing – Length	m	0.626	0.651	0.676

### Ball Matrix:

	4	3	2	1
A	A0	Vcc	R <sub>L</sub>	R <sub>H</sub>
B	$\overline{CS}$	SO	NC	R <sub>W</sub>
C	SCK	NC	NC	HOLD
D	SI	Vss	WP	A1

# X9271

## ORDERING INFORMATION

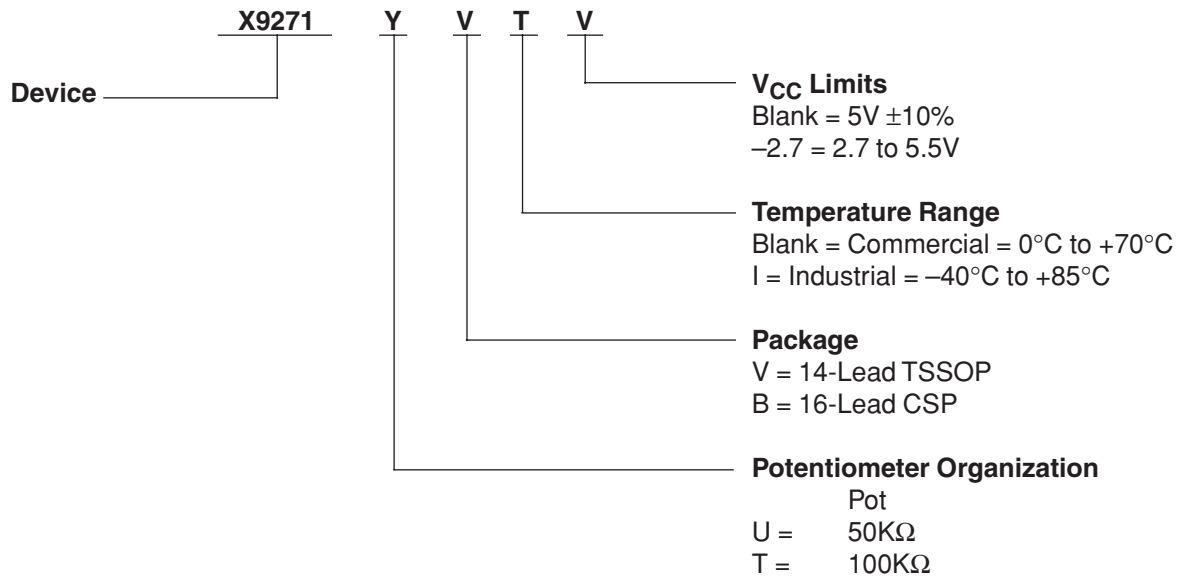

### LIMITED WARRANTY

©Xicor, Inc. 2003 Patents Pending

Devices sold by Xicor, Inc. are covered by the warranty and patent indemnification provisions appearing in its Terms of Sale only. Xicor, Inc. makes no warranty, express, statutory, implied, or by description regarding the information set forth herein or regarding the freedom of the described devices from patent infringement. Xicor, Inc. makes no warranty of merchantability or fitness for any purpose. Xicor, Inc. reserves the right to discontinue production and change specifications and prices at any time and without notice.

Xicor, Inc. assumes no responsibility for the use of any circuitry other than circuitry embodied in a Xicor, Inc. product. No other circuits, patents, or licenses are implied.

### TRADEMARK DISCLAIMER:

Xicor and the Xicor logo are registered trademarks of Xicor, Inc. AutoStore, Direct Write, Block Lock, SerialFlash, MPS, and XDCP are also trademarks of Xicor, Inc. All others belong to their respective owners.

### U.S. PATENTS

Xicor products are covered by one or more of the following U.S. Patents: 4,326,134; 4,393,481; 4,404,475; 4,450,402; 4,486,769; 4,488,060; 4,520,461; 4,533,846; 4,599,706; 4,617,652; 4,668,932; 4,752,912; 4,829,482; 4,874,967; 4,883,976; 4,980,859; 5,012,132; 5,003,197; 5,023,694; 5,084,667; 5,153,880; 5,153,691; 5,161,137; 5,219,774; 5,270,927; 5,324,676; 5,434,396; 5,544,103; 5,587,573; 5,835,409; 5,977,585. Foreign patents and additional patents pending.

### LIFE RELATED POLICY

In situations where semiconductor component failure may endanger life, system designers using this product should design the system with appropriate error detection and correction, redundancy and back-up features to prevent such an occurrence.

Xicor's products are not authorized for use in critical components in life support devices or systems.

1. Life support devices or systems are devices or systems which, (a) are intended for surgical implant into the body, or (b) support or sustain life, and whose failure to perform, when properly used in accordance with instructions for use provided in the labeling, can be reasonably expected to result in a significant injury to the user.
2. A critical component is any component of a life support device or system whose failure to perform can be reasonably expected to cause the failure of the life support device or system, or to affect its safety or effectiveness.